

FIS GAS SENSOR SP-42A

for REFRIGERANT DETECTION(R134a,R-410a,R-407c)

The SP-42A is a tin dioxide semiconductor gas sensor which has a high sensitivity to HFCs (e.g. Freon: R-134a) with improved cross sensitivity to other gases. This model is suitable for R-134a, R-410a, R-407c and other new freon family which contain R-134a.

Structure

Gas sensitive semiconductor material is formed on the alumina substrate on which the gold electrodes are printed. A thick film heater of ruthenium oxide is printed on the reverse of the substrate and placed in the plastic housing (Fig 1).

Operating conditions

Fig 2 shows the standard operating circuit for this model. The change of the sensor resistance (R_S) is obtained as the change of the output voltage across the fixed or variable resistor (R_L). In order to obtain the best performance and specified characteristics, the values of the heater voltage (V_H) circuit voltage (V_C) and load resistance (R_L) must be within the range of values given in the standard operating conditions shown in the Specification table on the next page.

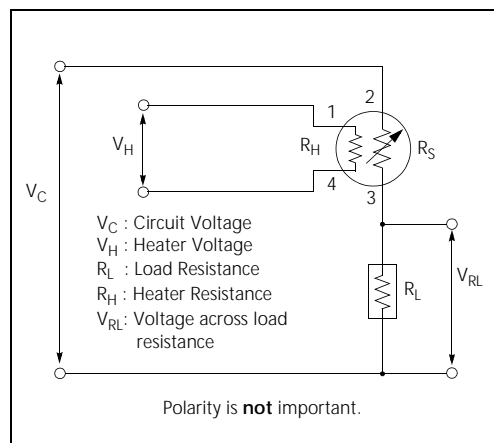

Fig 2. Standard circuit

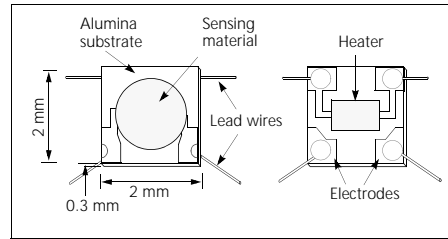

Fig 1a. Sensing element

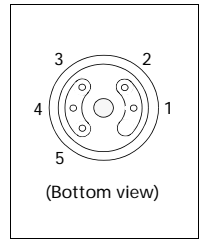

Fig 1c. Pin Layout

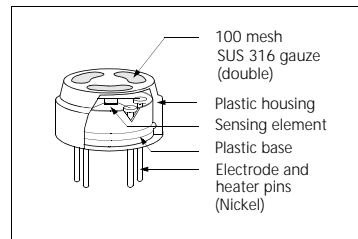

Fig 1b. Configuration

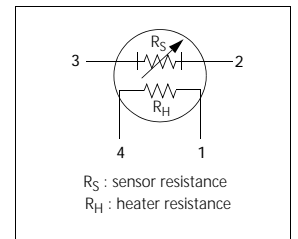

Fig 1d. Equivalent circuit

Sensitivity characteristics

Fig 3 shows the sensitivity characteristics curves of the SP-42A (typical data). Sensitivity characteristics of the FIS gas sensors are expressed by the relationship between the sensor resistance and gas concentration. The sensor resistance decreases with an increase of gas concentration based on a logarithmic function.

The sensitivity characteristics of the SP-42A is specified by the following parameters.

- Sensor resistance level: at R-134a 100 ppm
- Sensor resistance change ratio: between R-134a 100 ppm and 300 ppm

See the specification table on the next page for further details.

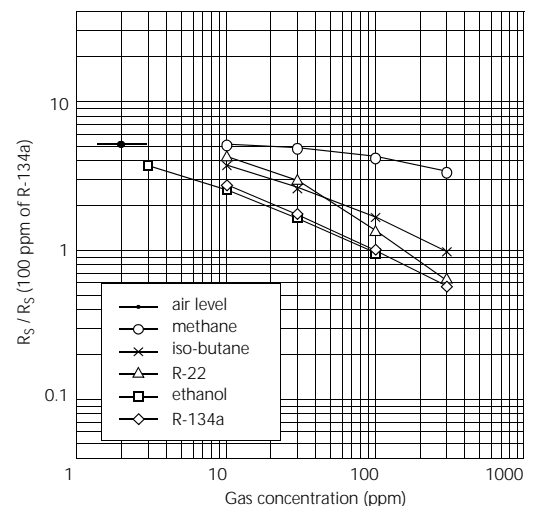

Fig 3. Sensitivity characteristics

Specifications

A. Standard Operating conditions

Symbol	Parameter	Specification	Conditions etc.
V_H	Heater voltage	$5.0\text{ V} \pm 4\%$	AC or DC
V_C	Circuit voltage	$5.0\text{ V} \pm 4\%$	AC or DC
R_L	Load resistance	Variable	$P_S < 15\text{ mW}$
R_H	Heater resistance	$40\ \Omega \pm 2\ \Omega$	at room temperature
P_H	Heater power consumption	400 mW (Typical value)	$P_H = V_H^2 / R_H$
P_S	Power dissipation of sensing element	Less than 15 mW	$P_S = \frac{(V_C - V_{RL})^2}{R_S}$

B. Environmental conditions

Symbol	Parameter	Specification	Conditions etc.
T_{ao}	Operating temperature	$-10\text{ }^\circ\text{C}$ to $60\text{ }^\circ\text{C}$	Recommended range
T_{as}	Storage temp	$-20\text{ }^\circ\text{C}$ to $70\text{ }^\circ\text{C}$	
RH	Relative humidity	Less than 95% RH	
(O_2)	Oxygen concentration	21% (Standard condition) The sensitivity characteristics are influenced by the variation in oxygen concentration.	Absolute minimum level: more than 18%

C. Sensitivity characteristics

Model	SP-42A-00		
Symbol	Parameter	Specification	Conditions etc.
R_S	Sensor resistance	4k Ω to 40k Ω	at 100 ppm of R-134a
β	Ratio of sensor resistance	0.50 to 0.65	$\frac{R_S \text{ at } 300 \text{ ppm of } 134a}{R_S \text{ at } 100 \text{ ppm of } R-134a}$
R/Rair	Resistance change in gas/air	≤ 0.40	$\frac{R_S \text{ at } 100 \text{ ppm of } 134a}{R_S \text{ in air}}$
Standard Test Conditions: Temp: $20\text{ }^\circ\text{C} \pm 2\text{ }^\circ\text{C}$ V_C : $10.0\text{ V} \pm 1\%$ Humidity: $65\% \pm 5\%$ (in clean air) V_H : $5.0\text{ V} \pm 1\%$ R_L : $10\text{ k}\Omega \pm 5\%$ Pre-heating time: more than 48 hours			

D. Mechanical characteristics

Items	Conditions	Specifications
Vibration	Frequency: 100 cpm	Should satisfy the specifications shown in the sensitivity characteristics.
	Vertical amplitude: 4 mm	
	Duration: 1 hour	
Shock	Acceleration: 100 G	
	Number of impacts: 5 times	

Dimensions

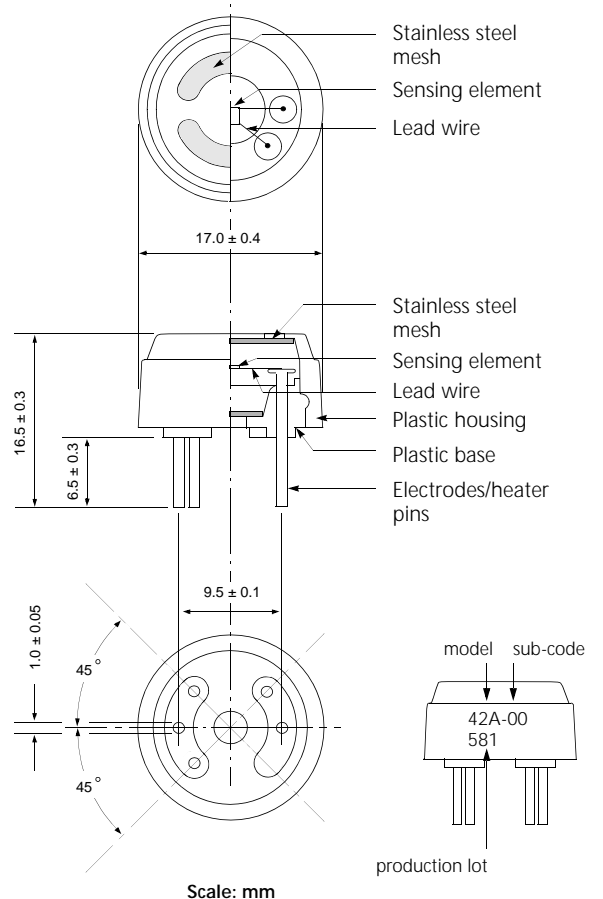

E. Parts and Materials

No.	Parts	Materials
1	Sensing element	Tin dioxide (SnO ₂)
2	Substrate	Alumina (Al ₂ O ₃)
3	Lead wire	Noble metal alloy (Au-Pd-Mo)
4	Heater	Ruthenium oxide (RuO ₂)
5	Electrode	Gold (Au)
6	Plastic housing	Nylon 46 (UL94HB)
7	Plastic base	Nylon 66 (UL94HB)
8	Stainless steel mesh	SUS 316 (100 mesh, double)
9	Heater/electrode pins	Nickel

Please contact

March 2006

FIS Inc.
3-36-3, Kitazono
Itami, Hyogo
664-0891 Japan

Tel: +81-72-780-1800
Fax: +81-72-785-0073
<http://www.fisinc.co.jp>